

Golden Arduino Board

Project Overview:

Purpose: The purpose of this board is to create our own improved version of an arduino using readily available components. The “golden” board should demonstrate 20-50% less switching noise and less than 10% of the near field emissions when compared to a commercial Arduino board. We also gain practice with the entire design flow as we begin with component research and progress all the way to assembly and testing.

POR:

- Follows best design practices
 - Utilizes test points for debugging
 - Has decoupling capacitors in close proximity to power pins
 - Short trace lengths
 - Copper filled return plane
 - Minimizes usage and length of crossunders
 - Has Isolation switches
 - Utilizes silkscreen to label key features
- Follows best measurement practices
- Shall not be larger 3.9 inches by 3.9 inches
- Uses 1206 components
- Powered through either a 5V barrel jack or a micro-USB cable
- Allows an operator to measure the in-rush current through two test points
- Utilizes a TVS to reduce likelihood of electro static discharge causing damage
- Has header pins with the same spacing as a commercial Arduino Uno to allow for shields to work universally
- Has ICSP header pins to allow for easy bootloading
- Has a reset button
- Has a ferrite LC filter to reduce noise on the AVCC of the ATmega328
- Uses a 12MHz crystal oscillator to operate a CH340G USB to UART controller
- Converts 5V to 3.3V using an LDO regulator

Schematic:

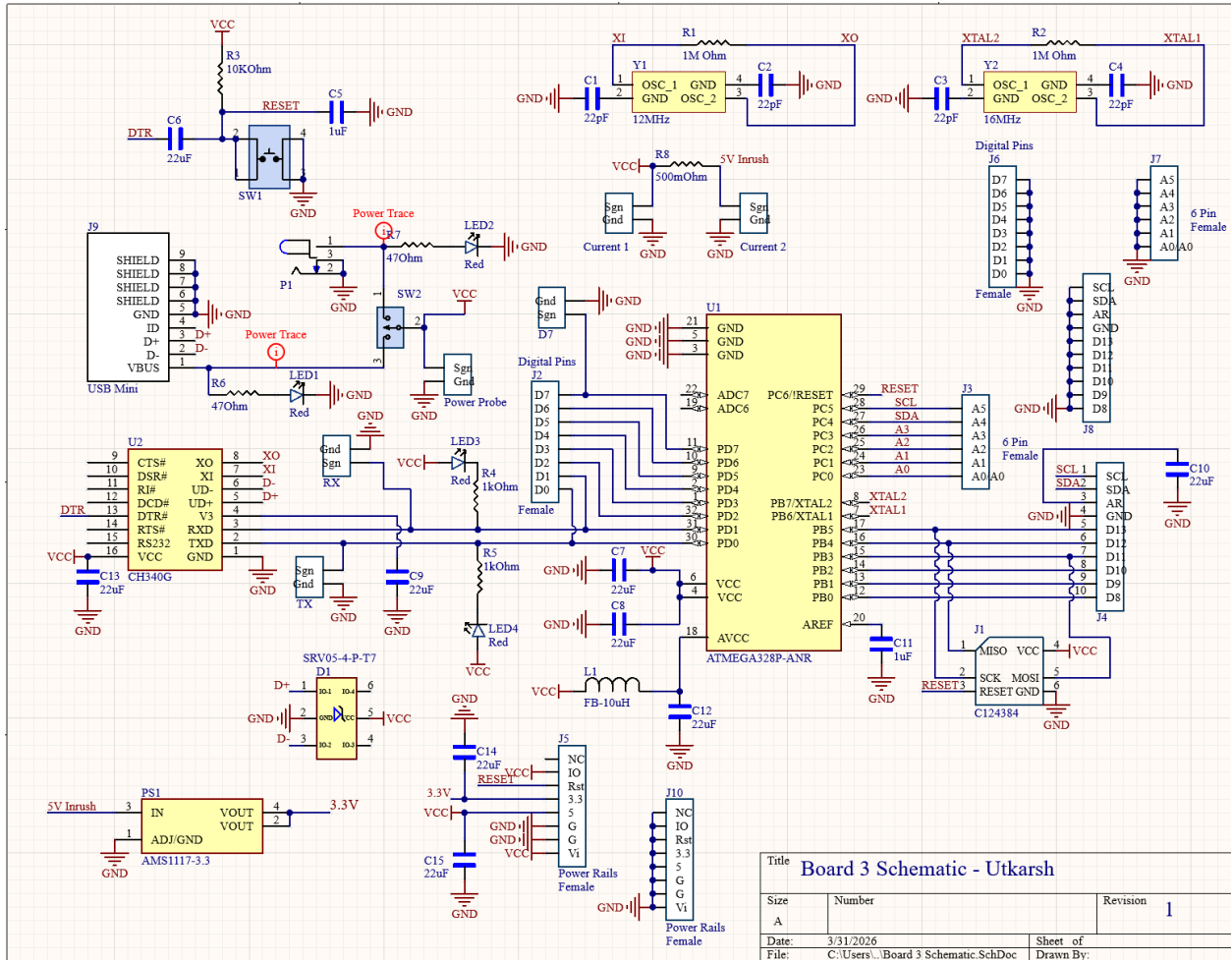

Figure 1: Schematic of the design in Altium Designer

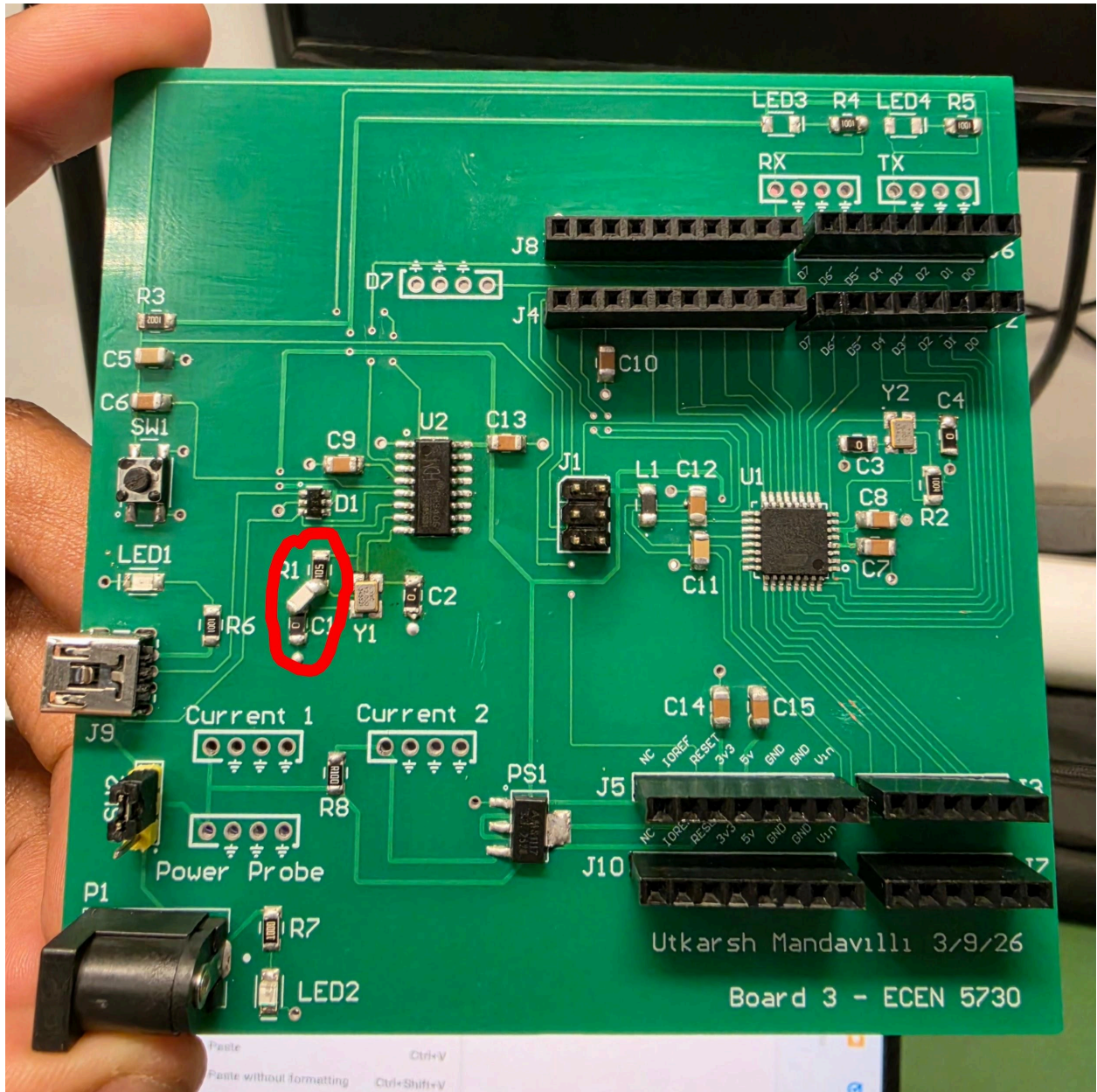
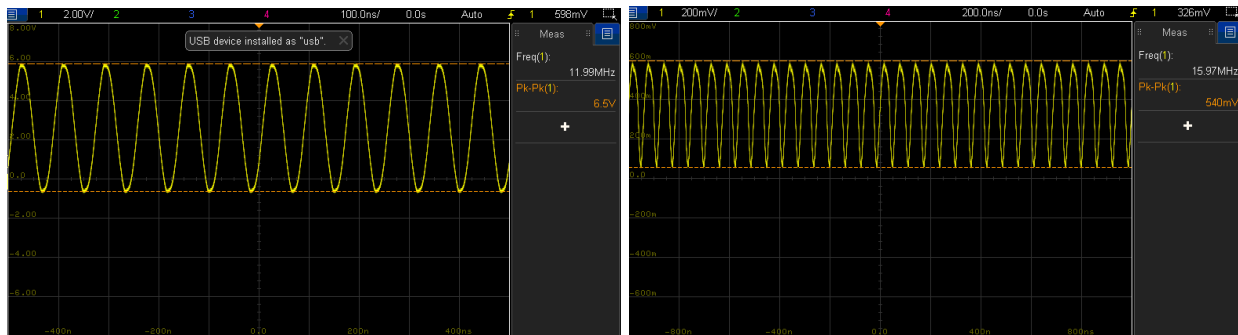

Figure 3: Final Soldered Board. Notice the capacitor connected to the 12 MHz clock circled in red. This was done in order to fix an issue that we will discuss shortly.

Bring Up and Validation of Board:

Before doing any analysis it is important to note that this board required a lot of debugging before we were able to get it running properly. This is quite common every year for this specific project due to its complexity and human error. Although we thoroughly checked the schematic and got it approved by TAs we still made one mistake. The 2 clock circuits on the board utilize 22pF capacitors to lock their frequencies at 12 and 16 MHz and prevent them from reaching higher frequency oscillations. One end of these capacitors are supposed to be placed in parallel with the 1M Ohm resistor and the other end should be grounded. In the schematic however, we can see that the capacitors are instead connected to the ground pins of the clocks. Upon assembling the board, the issue was diagnosed quickly and we were able to work around this by soldering the capacitors to different pads. This fix allowed for the board to work properly and forced the clock circuits to oscillate at the correct frequencies.



Figures 4&5: Scope Measurements of the 12 and 16 MHz clocks respectively.

The frequency for both clocks is as expected. The waveforms are clean and lack noise.

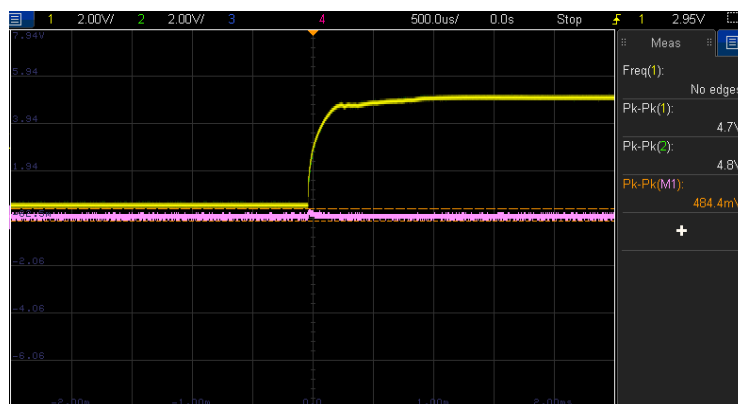

Figure 6: Green is measurement taken at Current 1 and yellow is taken at Current 2. A math function is used to subtract the two channels and is shown in pink.

This was used to calculate the inrush current of the circuit when turned on. Since we used a 100m Ohm resistor and we have a voltage drop of 484.4 mV, we get an inrush current of 4.84A.

For all of the testing we must use the following code snippet and shield to measure switching noise and near-field EMFs.

```

void setup() {  DDRB
= B00111111;
pinMode(7, OUTPUT);
digitalWrite(7, LOW);
}
void loop() {  PORTB
= B00111101;
delayMicroseconds(4);
PORTB = B00000001;
delay(1);
digitalWrite(7,
HIGH);
delayMicroseconds(400);
digitalWrite(7, LOW);
delay(10);
}
        
```

Figures 7&8: Arduino code and Shield to place on top of the “golden” board.

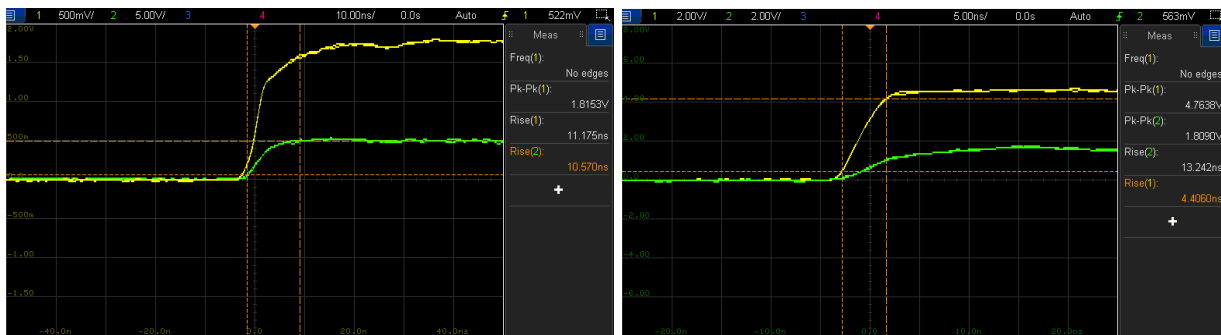

Figures 9&10: Switching noise of the quiet high and low lines on the golden arduino shown on the left. Switching noise on the quiet high and low lines of the commercial arduino shown on the right. In both cases, yellow represents quiet high and green represents quiet low. They both trigger on the rising edges as well.

The scales of both scope captures are not identical, but we can see that there is minimal switching noise in both cases.

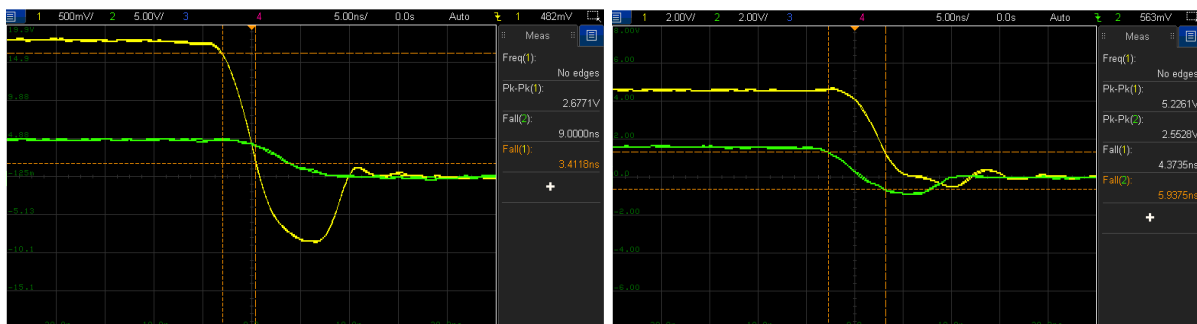

Figures 11&12: Switching noise of the quiet high and low lines on the golden arduino shown on the left. Switching noise on the quiet high and low lines of the commercial arduino shown on the right. In both cases, yellow represents quiet high and green represents quiet low. They both trigger on the falling edges in this case.

Due to differing scales when taking measurements, it seems like our “golden” board has much more noise of the quiet high line, but if we take a closer look we can see that this drop is quite minimal and is actually smaller than the commercial arduino. This is because the fall time of the golden arduino is lower which means that there is much higher instantaneous current.

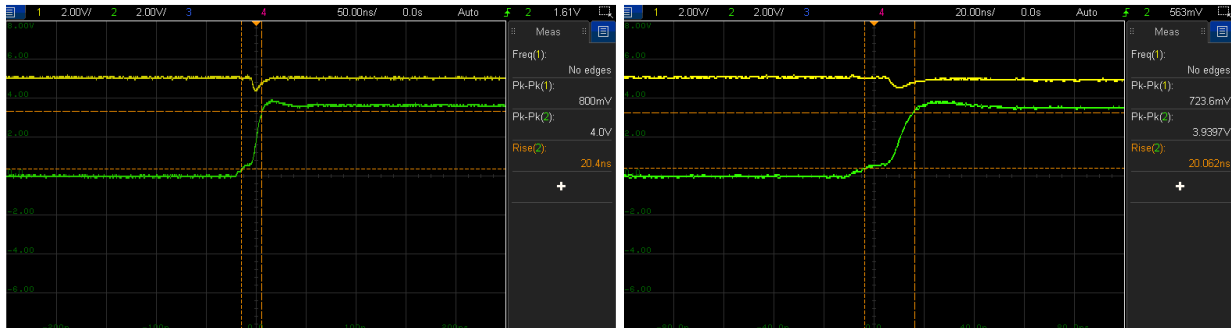

Figures 13&14: Voltage droop on the 5V power line (Yellow) when driving the slammer circuit (Green). “Golden” arduino shown on the left and commercial arduino shown on the right.

There is no difference between our board and the commercial one in terms of noise on the power rails. They both have similar rise times and are measured on the same scale. This means that both boards used the proper decoupling capacitors.

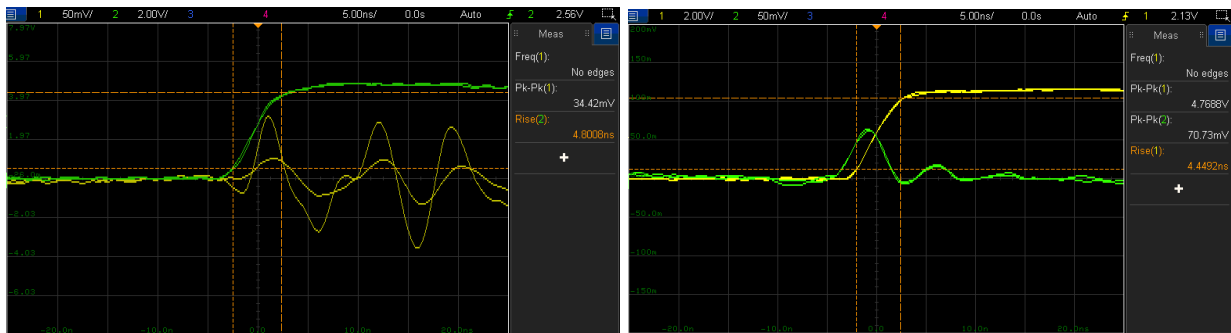

Figures 15&16: Near-field EMF measurements of the golden board on the left and commercial board on the right. Pin 13 output shown in green on the left and in yellow on the right.

If you compare the peak to peak voltages of the noise generated by near-field emissions, we can clearly see that the golden board has a much lower value than the commercial board. This indicates that it is better able to handle the inductances caused by external loops.

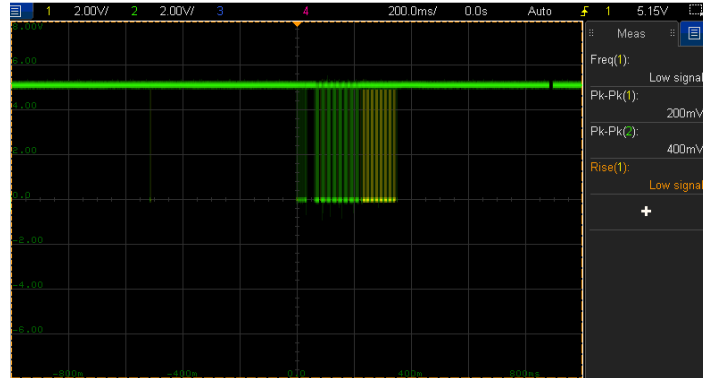

Figure 17: RX line shown in green and TX line shown in yellow.

This figure shows that the ATMEGA is receiving a signal on the RX line from the CH340 and then proceeds to send information back on the TX line.

Conclusion:

Based on our findings we can see that our board performed quite well despite the challenges encountered in assembly and testing. The “golden” board was able to outperform the commercial board in most cases and showed a significant improvement in switching noise and near-field EMF noise. This means that we were able to achieve our goal.