

In this lab we created a slammer circuit on a solderless breadboard using a MOSFET that drew from a 9V power rail. This lab examines switching noise from the transistor when using an opamp and a digital pin from an arduino. Another objective of this lab was to understand the effect of decoupling capacitors on loop inductances in the power rails and how they can mitigate voltage droop. The following schematic was used to build the circuit.

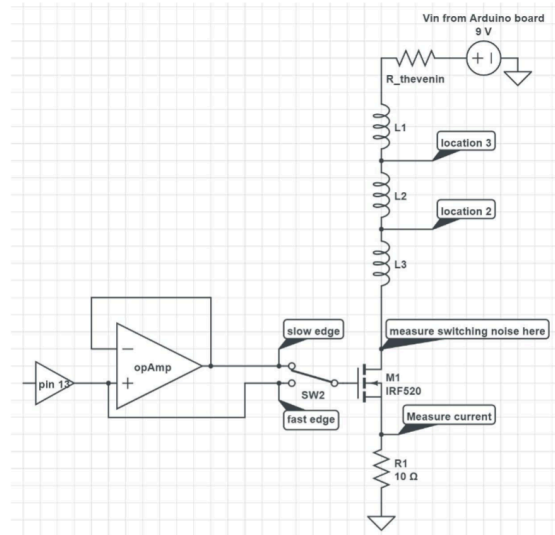

Figure 1: Schematic of Slammer Circuit from the Lab Manual. Inductors are due to the inherent inductance of the power rails.

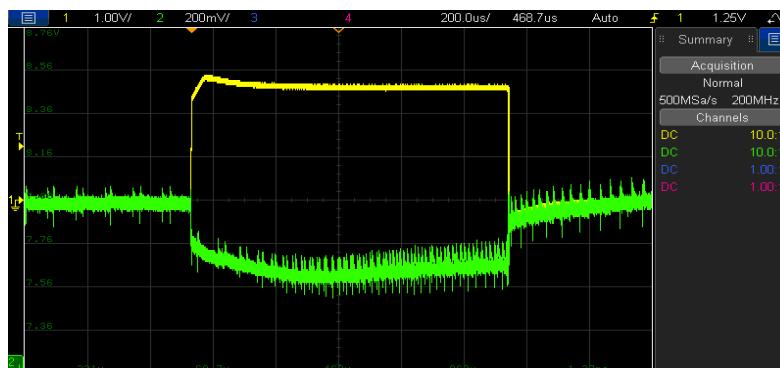
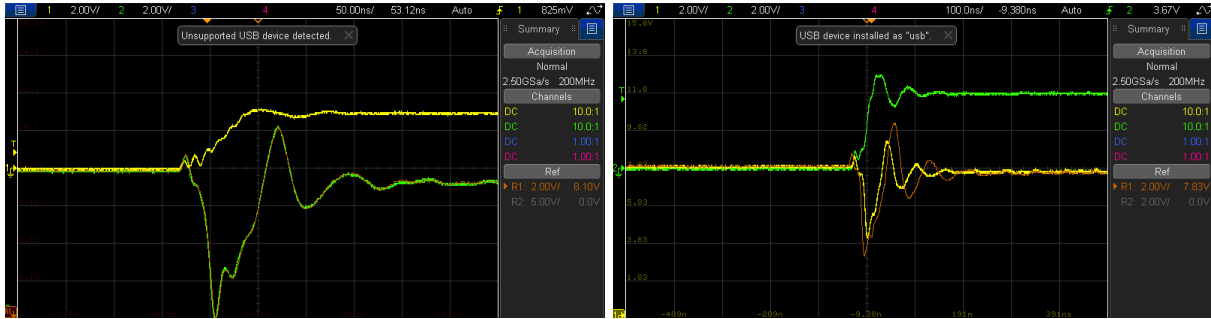

Figure 2: This is a scope measurement of the 9V Power Rail (Green) and the Current through the 10 Ohm Resistor (Yellow) when using the faster switching speed.



Figures 3&4: The left image is the scope measurement of the power lines (Green) and the current through the resistor (Yellow) without the use of a decoupling capacitor. The image on the right is the same scope measurement with the use of a 1uF Capacitor. The reference is from the image on the left.

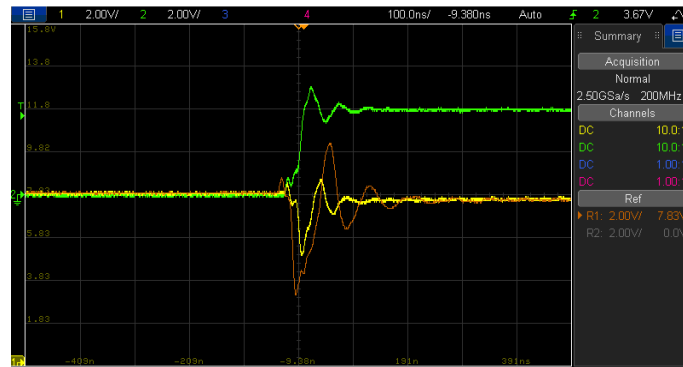

Figure 5: Scope measurement using the 1000uF Capacitor compared to the measurement from figure 3.

The addition of capacitors makes a major change in the noise and the voltage droop, but the difference between the capacitors is less pronounced.

The Thevenin Resistance of this VRM can be calculated using the following formula, where the $V_{TH} = 9V$:

$$R_{Th} = \frac{V_{Th} - V_{Load}}{I} = \frac{9 - 8.10}{.810} = 1.1 \text{ Ohms}$$

The Loop Inductance is calculated using the following formula:

$$\Delta V = L \frac{dI}{dt} \quad 8.10 = L(.810/25ns) \quad L = .25\mu H$$

The higher switching speed doesn't affect the loop inductance but it does affect the delta V since it is a function of di/dt.

Increased switching speed can cause higher voltage spikes and more noise within the circuit. Placing a decoupling capacitor can help mitigate these spikes and reduce overall noise caused when switching. The value of the capacitor can also affect the results, but after a certain point there are diminishing returns. We also experimented with the location of the capacitors. Minimizing the distance from the capacitor and the power-utilizing components is key. Another possible solution is to decrease the switching speed, however this is generally dependent on the components used. Generally it is good practice to use decoupling capacitors and minimize trace lengths.